

## CO2-1 $\beta$ -decay spectroscopy of rare fission products with a $4\pi$ clover detector using an Isotope Separator On-Line KUR-ISOL

S. Sakakibara, Y. Miyazawa, T. Kuga<sup>1</sup>, M. Shibata<sup>2</sup> and A. Taniguchi<sup>3</sup>

Graduate School of Engineering, Nagoya University

<sup>1</sup>School of Engineering, Nagoya University

<sup>2</sup>Radioisotope Research Center, Nagoya University

<sup>3</sup>Institute for Integrated Radiation and Nuclear Science, Kyoto University

**INTRODUCTION:** The decay data of the fission products are important for evaluating decay heat and determining the structure of neutron-rich nuclei. Many neutron-rich nuclei with mass numbers near 150 do not have detailed decay schemes due to their short half-lives and low fission yields. The nuclide  $^{157}\text{Nd}$  was proposed to have a half-life of 1.15 s by Wu *et al.* with  $\beta$ -particle measurements [1] and a level scheme of the daughter nuclide  $^{157}\text{Pm}$  was reported by Bhattacharyya *et al.* by the prompt  $\gamma$ -ray measurements of spontaneous fission fragment of  $^{252}\text{Cf}$  [2], but, no  $\gamma$  rays associated with the  $\beta$ -decay of  $^{157}\text{Nd}$  were reported. To identify the  $\gamma$  rays associated with the  $\beta$ -decay of  $^{157}\text{Nd}$ ,  $\beta$ - $\gamma$  coincidence measurements were performed using a high-efficiency clover detector coupled with  $\beta$ -ray detectors with On-line Isotope Separator KUR-ISOL.

**EXPERIMENTS:** 72 mg of 93% enriched  $^{235}\text{UF}_4$  target was inserted at the through-hole facility in Kyoto University Reactor. The nuclei of interest were produced by thermal neutron-induced fission of  $^{235}\text{U}$ . The nuclei were transported by He- $\text{N}_2$  gas jets and ionized in a thermal ionization ion source. The mass-separated radioactive beams were collected on a thin Mylar tape and periodically transported to the center of the detector by a computer-controlled tape transport system, and were measured with detectors. The clover detector has four large Ge crystals with a diameter of 80 mm and a length of 90 mm arranged in the shape of a four-leaf clover around a through hole with a diameter of 15 mm. Two identical  $\beta$ -ray detectors were made of plastic scintillators 105 mm long, 12.6 mm wide, and 1 mm thick, contacted with a semi-cylindrical light guide with a radius of 6.5 mm. A  $3\times 3$  mm<sup>2</sup> MPPC (Multi-Pixel Photon Counter) module C13367 made by Hamamatsu Photonics was mounted on the end of the light guide. The  $\beta$ -detectors were inserted in a through-hole of the clover detector. The whole detector was shielded with 10 cm thick lead bricks and 10 cm thick boron-doped polyethylene blocks outside them to reduce background neutrons and  $\gamma$ -rays. Data were recorded on APV8008 and APV8016 DSP data acquisition systems made by Techno AP Corporation with list mode including time information. The nuclide  $^{157}\text{Nd}$  was measured for 39 hours with the both periods of collection and measurement were set 3.0 s. After the experiments, time dependent spectra were extracted to analyze the decay properties of  $\gamma$  rays and KX-rays.

**RESULTS and DISCUSSION:** To identify the  $\gamma$  rays associated with the  $\beta$ -decay of  $^{157}\text{Nd}$ , the decay properties

of the  $\gamma$  rays and Pm KX-rays, and also their coincidence relations were analyzed. The coincidence time was set to 700 ns. Fig.1 shows the  $\gamma$ -ray singles and  $\beta$ - $\gamma$  coincidence spectra for the A=157 radioactivities. It was confirmed that nuclides with adjacent mass numbers 156 and 158 did not mix in the mass-separated A=157 beams. In the  $\beta$ - $\gamma$  coincidence spectrum, the background radiation such as the  $\gamma$ -ray associated with the decay of  $^{41}\text{Ar}$  produced with  $^{40}\text{Ar}(n, \gamma)$  reaction or capture  $\gamma$ -rays of Ge crystals by the neutron in the reactor room were reduced effectively. The peaks were analyzed using the peak fitting program developed by Yamada *et al.* [3] Most  $\gamma$  rays and KX-rays were originated from the  $\beta$ -decay of daughter nuclide  $^{157}\text{Pm}$  ( $T_{1/2}=10.56$  s) [1] and ground daughter nuclide  $^{157}\text{Sm}$  ( $T_{1/2}=8.03$  m) [4]. However, from the analysis of the time dependent  $\beta$ - $\gamma$  coincidence spectra each 1 s as shown in Fig.1(b), and also the add-back of four crystals, and singles spectra, the 66 keV  $\gamma$ -ray and the  $\text{K}\alpha$ X-ray region correspond to Pm were observed to disintegrate with a half-life shorter than  $^{157}\text{Pm}$ . In the prompt  $\gamma$ -ray measurements with  $^{252}\text{Cf}$  [2], the 66 keV  $\gamma$ -ray were proposed as the transition from the first excited state to the ground state in  $^{157}\text{Pm}$ . The  $\gamma$  ray is possible to be associated with the  $\beta$ -decay of  $^{157}\text{Nd}$ . In addition, the  $\text{K}\alpha$ X-ray region of Pm also disintegrate with almost the same half-life. The precise analyses are in progress.

### REFERENCES:

- [1] J. Wu *et al.*, Phys. Rev. Lett., **118** (2017) 072701.
- [2] S. Bhattacharyya *et al.*, Phys. Rev., **C98** (2018) 04316.
- [3] S. Yamada, KURRI-TR-430.
- [4] N. Nica, NDS. **132** (2016)1.

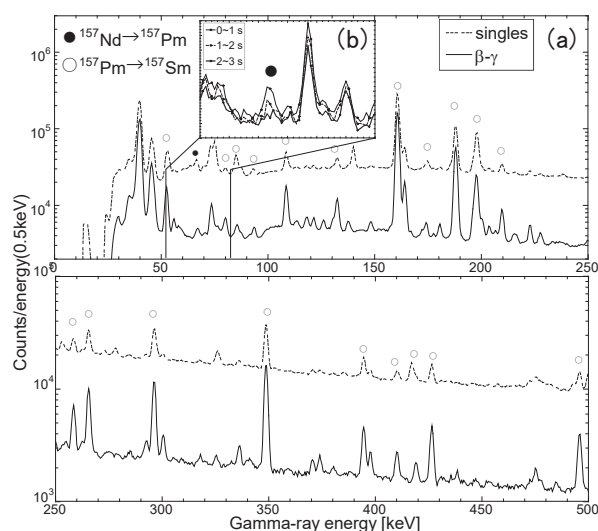

Fig. 1. Singles and  $\beta$ - $\gamma$  coincidence spectra for the mass-separated beam of A=157 (a). The  $\gamma$  rays marked as  $\circ$  are associated with the decay of  $^{157}\text{Pm}$  and that of  $\bullet$  is possible to be associated with the decay of  $^{157}\text{Nd}$ . The inset (b) shows the time dependent  $\beta$ - $\gamma$  coincidence spectra each 1 s.

## CO2-2 Development and test of a current-mode $^3\text{He}$ gas neutron detectors for an intense neutron beam

T. Matsumoto, S. Manabe, A. Masuda, H. Harano, J. Hori<sup>1</sup>, K. Terada<sup>1</sup>

National Metrology Institute of Japan, National Institute of Advanced Industrial Science and Technology

<sup>1</sup>Institute for Integrated Radiation and Nuclear Science, Kyoto University

**INTRODUCTION:** It is necessary to measure the neutron flux for a large dynamic range to connect between a BNCT field in a hospital and a neutron calibration field in the National Institute of Advanced Industrial Science and Technology (AIST). The difference of neutron fluxes between the BNCT field and the calibration field is more than 5 orders of magnitude. We have developed a new  $^3\text{He}$  gas detector with a thimble ion chamber with a 10-mm diameter and a 10-mm length. Unlike ordinary ionization chambers that are used for gamma-ray measurements, the neutron detector has a structure that allows for gas replacement and gas sealing. The gas detector is expected to be high radiation resistance in comparison with a photo-multiplier tube in the scintillation detector [1]. In the present study, the sensitivity of the neutron detector to thermal and epi-thermal neutrons will be experimentally confirmed from time-of-flight (TOF) measurements as a first step.

**EXPERIMENTS:** A collimated neutron beam with 30-mm diameter was obtained by the photo neutron reaction using a tantalum target with a water moderator at the KURNS Linac [2]. A  $\text{BF}_3$  proportional counter was used as a neutron monitor. Figure 1 shows a typical experimental setup. The chamber of neutron detector was filled with  $^3\text{He}$  gas at 1 atm and  $\text{N}_2$  gas at 0.2 atm. A relative gas monitor was also installed to check for gas pressure fluctuations due to gas leakage. The neutron detector was measured by means of the TOF method to confirm that thermal and epi-thermal neutrons were detected. The measurements were performed for both pulse and current modes. In the pulse mode, signals from the  $^3\text{He}$  proportional counter were obtained using a pre-amplifier (ORTEC 142PC) and main amplifier (ORTEC 570). High voltage (+500 V) was applied to the center electrode. In the current mode, the signals were obtained using a current integrator (ORTEC 439). High voltage (+500) was applied to the outer electrode to suppress the dark current. Finally, TOF data were extracted using a multi-stop time to digital converter and a multi-channel analyzer (Fast Com Tec MPA3).

**RESULTS:** Figure 2 shows TOF results obtained from the measurements in the pulse mode for conditions with and without neutron beam. From figure 2, the structure of thermal bump is clearly observed. Thermal and epi-thermal neutrons were successfully detected. Therefore, it was confirmed that it was not a mistake as the design of the neutron detector structure. On the other hand, it is also found that the background including gamma rays and electric noise observed without the neutron beam is very large. Furthermore, in the current mode, only a very small current on the order of pA was obtained. Because of the small size of the chamber of the neutron detector being

developed, with the gas composition used in the present experiments, many of the protons and tritons produced by the  $^3\text{He}(n,p)\text{T}$  reaction were not completely stopped inside the chamber. Therefore, the pulse height output in the pulse mode was very small and the background to signal ratio was poor. For the same reason, the output current was very small in the current mode. We will obtain heavier mass number gases such as Kr and Ar, next year. By filling the chamber with heavier mass number gases instead of  $\text{N}_2$  gas, the outputs will be larger than those obtained in the present experiments because many of the protons and tritons produced by the  $^3\text{He}(n,p)\text{T}$  reaction will stop inside the chamber. We plan to use the neutron detector in the current mode. In that case, it is impossible to discriminate gamma rays from output signals. Therefore, a chamber filled with  $^4\text{He}$  instead of  $^3\text{He}$  will be prepared to subtract the gamma components.

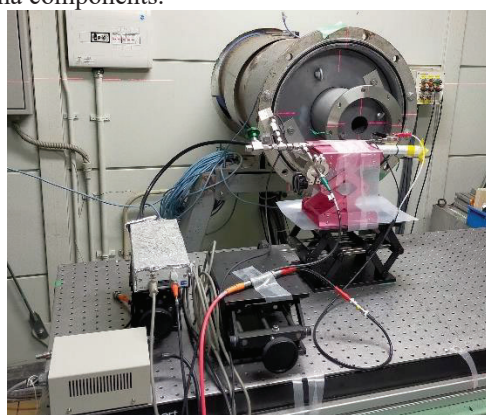

Fig. 1. Experimental setup for the neutron detector at approximately 12 m away from the target.

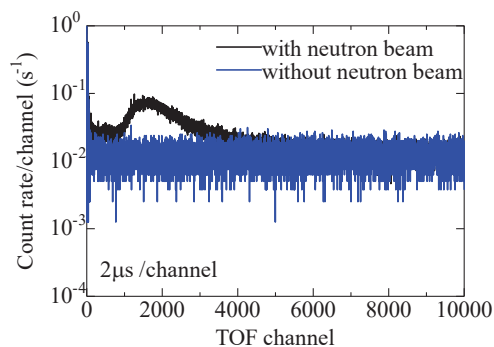

Fig. 2. TOF spectra obtained from the measurements in the pulse mode for conditions with and without neutron beam.

### REFERENCES:

- [1] T. Matsumoto *et al.*, Radiat. Prot. Dosim., **188** (1) (2020) 142.
- [2] K. Kobayashi *et al.*, Annu. Rep. Res. Reactorinst. Kyoto Univ., **22** (1989) 142.

This work was supported by JSPS KAKENHI (21H03755 and 19K12638).

## CO2-3 Development of neutron resonance analysis technique using a neutron time-of-flight method

J. Lee<sup>1</sup>, K. Hironaka<sup>1</sup>, M. Koizumi<sup>1</sup>, J. Hori<sup>2</sup>, T. Sano<sup>3</sup>, and Y. Matsuo<sup>3</sup>

<sup>1</sup>Integrated Support Center for Nuclear Nonproliferation and Nuclear Security, Japan Atomic Energy Agency

<sup>2</sup>Institute for Integrated Radiation and Nuclear Science, Kyoto University

<sup>3</sup>Atomic Energy Research Institute, Kindai University

**INTRODUCTION:** Passive neutron and gamma-ray detectors are widely used for nuclear material measurements in nuclear safeguards and security. However, those techniques could not directly apply for measurement of samples in a shield or with radioactive accompanies. In order to overcome the difficulties, the Japan Atomic Energy Agency (JAEA) is developing neutron interrogation techniques [1]. Neutron resonance transmission analysis (NRTA) is one of the developing active non-destructive assays (NDA) techniques, in which pulsed neutron beam is used to measure a neutron transmission TOF spectrum [2,3]. From the observed nuclide characteristic resonance spectrum, the thickness of each nuclide can be deduced. Nevertheless, measurement of trace fissile materials, such as <sup>235</sup>U, and <sup>239</sup>Pu, in a sample can be still difficult. To improve the sensitivity to those materials, a use of fission neutron measurement has been proposed. Hereafter, we call the technique as neutron resonance fission neutron analysis (NRFNA), in which fast neutrons are measured by using neutron TOF technique. Pulse shape discrimination (PSD) plastic scintillation detectors [4] were employed to distinguish fission neutron events from gamma ray events. In this paper, we report a demonstration experiment of NRFNA carried out at the KURNS-LINAC using <sup>nat</sup>U samples.

**EXPERIMENTS:** The KURNS-LINAC was operated with an acceleration energy of about 30 MeV, and an average current of about 42  $\mu$ A. Pulsed neutrons were produced by the impact of the accelerated electrons of 50-Hz repetition rate and 2- $\mu$ s pulse width. The neutrons were slowed down in a moderator, then collimated and guided to a hut for 12-m TOF experiments. The <sup>nat</sup>U samples used were 1.5, 3.0, and 6.0 mm in thickness. Eight quadrangular and two hexagonal PSD plastic scintillation detectors (Eljen, EJ-276) were used for fast neutron detection as shown in Fig. 1. 20-mm Pb sheets were placed between the detectors and the sample to reduce the gamma ray events from the sample. The output signals of the detectors are directly sent to a digitizer (CAEN V1730D, 14 bit, 500 MSample/s). Processed data was recorded by a computer as a list data.

**RESULTS:** The achieved data were analyzed. Neutron and gamma ray events are discriminated [4]. Achieved TOF spectra for fission neutron and gamma ray are given in Fig. 2. The resonance peaks of 6.67, 20.87, 30.68, and 66.02 eV of the black line are from (n, $\gamma$ ) reactions of <sup>238</sup>U, and those of 1.13, 3.14, 3.62, 8.76, 12.39, 19.30, and 35.17 eV of red line are from (n,f) reactions of <sup>235</sup>U. Thermal bumps of <sup>235</sup>U and <sup>238</sup>U were also ob-

served at around 4 ms. Using the PSD scintillation detector system, we successfully separate neutron events from gamma ray events. Further analysis will be performed using Multilevel Resonance Parameter Least Square Fit (REFIT) to establish a method for quantitative analysis. A mutual analyzing method of NRFNA and NRTA will be studied because MRTA measurement can be performed simultaneously using neutron beams passing through the NRFNA system.

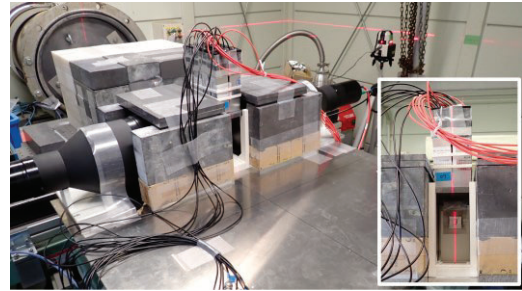

Fig. 1. Experimental setup of NRFNA. The red bricks surrounding the PSD scintillation detector system is for room background reduction.

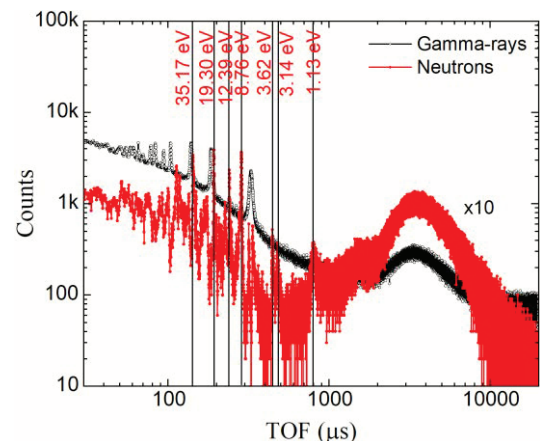

Fig. 2. TOF spectra obtained by the NRFNA experiment.

**ACKNOWLEDGEMENTS:** This research was implemented under the subsidy for “promotion of strengthening nuclear security and the like” of the MEXT (the Ministry of Education, Culture, Sports, Science, and Technology of the Japanese government).

### REFERENCES:

- [1] M. Koizumi *et al.*, Proc. of INMM & ESARDA Meeting 2021, #201.
- [2] P. Schillebeeckx *et al.*, Nuclear Data Sheets, **113**, (2012) 3054-3100.
- [3] H. Postma and P. Schillebeeckx, Neutron Resonance Capture and Transmission Analysis, John Wiley and Sons, 2009.
- [4] M. Koizumi *et al.*, Nucl. Instr. Methods. A, **1042** (2022)167424 .

## CO2-4 Technique of Transferring Radioactive Atomic Nuclei Implanted in Dry Ice Film

A. Taniguchi, P. Strasser<sup>1</sup> and M. Tanigaki

*Institute for Integrated Radiation and Nuclear Science,  
Kyoto University*

<sup>1</sup>*Muon Science Laboratory, IMSS, KEK*

**INTRODUCTION:** The nuclear charge radius is one of the fundamental parameters. It gives information about the effective interactions on the nuclear structure. Muonic atoms are an ideal tool for obtaining this parameter because the energy levels of the muon in a muonic atom can be accurately described by the electromagnetic interaction between the negative muon and the nucleus, taking into account the charge distribution of the nucleus, and the effect can be observed as the energies of the X-rays emitted from the muonic atom [1]. However, mainly because of the large amount of radioactivity required, the study of muonic atoms for unstable nuclei has made little progress. We have recently developed a new method for the high-efficiency production of muonic atoms by means of a solid film of hydrogen. In this method, negative muons ( $\mu^-$ ) are injected into a solid film of deuterium (D) in which nuclei of interest (A) have been implanted beforehand, resulting in the formation of muonic atoms via the highly-efficient muon transfer reaction:  $\mu^-D + A \rightarrow D + \mu^-A$ . The feasibility of this method was demonstrated for some stable isotopes and promising results were obtained [2]. In this study, the expected technical difficulties in applying this method to unstable nuclei, in particular the highly efficient recovery of residual radioactivities in the deuterium film after the experiments, are addressed using a radioactive-isotope beam from the Kyoto University Reactor-Isotope Separator On Line (KUR-ISOL) and a dry ice film instead of a solid hydrogen film.

**EXPERIMENTS:** At the beamline of KUR-ISOL, an apparatus was installed which is capable of implanting radioactivities in a dry ice film [3]. This apparatus consists of two cuboid movable copper blocks that can be cooled using liquid nitrogen (LN<sub>2</sub>) as a coolant and a CO<sub>2</sub> gas diffuser in the vacuum chamber. A film of dry ice is formed on the surface of a cooled block (catcher) by spraying CO<sub>2</sub> gas through the diffuser and radioactivities are implanted into the film. The amount of radioactivities transferred from the catcher to the other block (trap) are examined under different conditions of film formation. In recent experiments, to improve the reproducibility of the transfer efficiency, the film-forming parameters were more finely controlled by recording the vacuum level in the chamber and the temperatures of the copper blocks using a data logger. In addition, "standing collars" were attached on the four sides of the film-forming surface so that more CO<sub>2</sub> gas could be retained near the surface during film formation, and during transfer, the collars covered the catcher-trap gap to allow more CO<sub>2</sub> gas to agglomerate again on the trap block. However, until now, the thickness of the film has not been measured because the white film on the catcher

could be visually confirmed, even though the thickness is an important factor in considering the stop position of the implanted ions in the film.

In this experiment, two new gate valves were installed between the vacuum chamber and the two turbomolecular pumps at the apparatus. These valves isolate the vacuum chamber and prevent CO<sub>2</sub> gas from escaping, allowing the experiments to determine film thickness and try out new ways of forming films. A pressure transducer (Swagelok, PTI-S, pressure range: -0.1~0.3 MPa) was also mounted to measure the pressure in the chamber filled with CO<sub>2</sub> gas.

**RESULTS AND DISCUSSION:** Typically, 300 cc of CO<sub>2</sub> gas at 1 atm was gently sprayed through the diffuser onto the cooled catcher in film formation. It was estimated that 270 cc of CO<sub>2</sub> gas was used to form the film by comparing the pressure at which the isolated vacuum chamber was filled with a given amount of CO<sub>2</sub> gas with the pressure at which the film formed by spraying the same amount of gas sublimated. Assuming that a uniform film was formed on the catcher (25 × 25 mm) with this amount of gas, and using the density of dry ice (1.687 g/cm<sup>3</sup> at 77 K) [5], the thickness of the film was estimated to be approximately 0.39 mm. This suggests that when ideal dry ice is formed on the catcher, the film is thick enough for the implanted ions.

The transfer efficiencies of <sup>146</sup>Ce and <sup>146</sup>Pr from the catcher to the trap were obtained by detecting the  $\gamma$ -rays emitted from each of the blocks after implantation of about 10<sup>6</sup> ions of <sup>146</sup>LaO<sup>+</sup> into the dry ice film formed in the chamber isolated from the TMPs. (See ref [4,6] for details.) The 454 keV gamma-ray peak counts of <sup>146</sup>Pr for the catcher and for the trap were derived by taking into account the detection efficiency of each Ge detector and a ratio of the counts for the trap to those for the catcher was 4:1. This result was not as high as those of previous values [6] and was within the range of variation.

Experiments are needed to develop a highly efficient recovery method while searching for better conditions for dry ice film formation hereafter. In addition to the development, experiments are also planned to focus on the scattering of radioactivities during the implantation.

**ACKNOWLEDGMENTS:** This research was partially supported by the Ministry of Education, Science, Sports and Culture, Grant-in-Aid for Scientific Research (C) (24540303, Akihiro Taniguchi, and 15K05103, Akihiro Taniguchi).

### REFERENCES:

- [1] I. Angeli and K.P. Marinova, *At. Data Nucl. Data Tables*, **99** (2013) 69-95.
- [2] P. Strasser *et al.*, *Hyperfine Interact.*, **193** (2009) 121-127.
- [3] A. Taniguchi *et al.*, *KURRI Prog. Rep.* 2013, p.98.
- [4] A. Taniguchi *et al.*, *KURNS Prog. Rep.* 2019, p.4.
- [5] T.P. Mangan *et al.*, *Icarus*, **294** (2017) 201-208.
- [6] A. Taniguchi *et al.*, *KURNS Prog. Rep.* 2020, p.100.

## CO2-5 Validation Experiment of Thermal Neutron Scattering Law Data for Innovative Reactor

J. Hori<sup>1</sup>, Y. Takahashi<sup>1</sup>, T. Sano<sup>2</sup>, K. Terada<sup>1</sup>, and H. Yashima<sup>1</sup>

<sup>1</sup>Institute for Integrated Radiation and Nuclear Science, Kyoto University

<sup>2</sup>Atomic Energy Research Institute, Kindai University

**INTRODUCTION:** In order to consider the design of innovative reactors, accurate thermal neutron scattering laws (TSLs) for moderator materials are necessary. Calcium hydride is one of the candidate solid moderator materials of a small modular reactor (SMR) [1]. However, TSLs of CaH<sub>2</sub> are not evaluated and stored in JENDL-5 [2]. As for light water which is the most important moderator in a thermal reactor, TSLs were newly evaluated with the molecular dynamics simulation in JENDL-5 and modified remarkably from those of JENDL-4.0 [3]. Validation of the modified evaluated data is needed.

Pulse-neutron die-away (PNDA) experiments have been reported as promising benchmarks for validating TSLs in the previous work [4]. In this study, we suggested a new method to detect the pulse-neutron die-away time by measuring the neutron capture gamma-rays directly. The leakage neutrons from the sample assembly were also measured with a TOF method simultaneously.

**EXPERIMENTS:** The experiment was performed at the 46-MeV electron linear accelerator in Institute for Integral Radiation and Nuclear Science, Kyoto University. Pulsed fast neutrons were produced from a water-cooled Ta target as a photo-neutron source without moderator. A beam width and a frequency were 100 ns and 200 Hz, respectively. A Cd sheet of 0.5 mm in thickness was inserted into the TOF beam line to suppress overlap of thermal neutrons from the previous pulses. The flight path used in the experiment is in the direction of 135 degrees to the electron beam. The pulsed neutron beam was collimated to 30 mm in diameter.

Each sample assembly was placed at about 10 m from the Ta target. The cylindrical containers made of aluminum were filled with light water or CaH<sub>2</sub> powder. The diameters of the containers were 20 cm and 6 cm for light water and CaH<sub>2</sub> powder, respectively.

The 2.2MeV gamma-rays emitted from the neutron capture by hydrogen in the assembly were measured by a BGO detector. The timing information means die-away time distribution in the assembly. On the other hands, the neutrons moderated in the assembly were also measured by a <sup>6</sup>Li-glass detector with a TOF method. The distance between the center of the assembly and the surface of the <sup>6</sup>Li-glass detector was 40 cm.

**RESULTS:** The comparisons of the preliminary experimental results with the calculated ones using JENDL-4.0 and JENDL-5 are shown in Figs. 1 and 2. The Calcula-

tions were performed using the MCNP code. The calculated values considering the S( $\alpha,\beta$ ) are close to the experimental results compared to the calculated with the free-gas model. In Fig. 2, the present results show a tendency to support JENDL-5 more than JENDL-4.0.

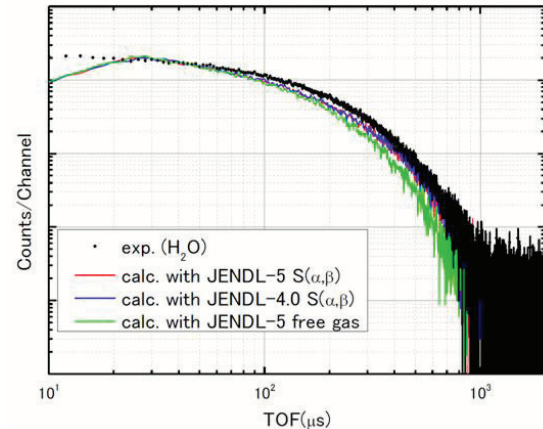

**Fig.1.** Comparison of the experimental neutron die-away time distribution in the light water assembly with the calculated ones.

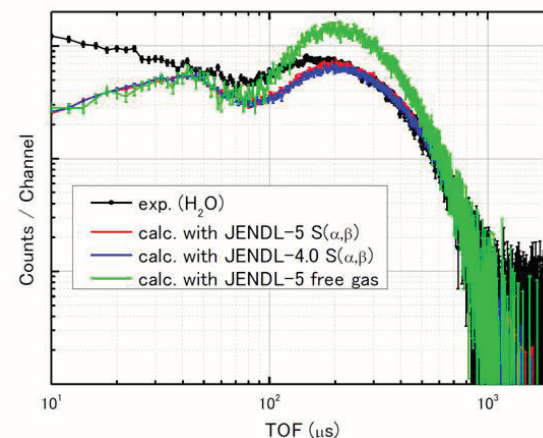

**Fig.2.** Comparison of the experimental neutron TOF spectrum from light water assembly with the calculated ones.

### ACKNOWLEDGEMENT:

This work is supported by the Innovative Nuclear Research and Development Program from the Ministry of Education, Culture, Sports, Science and Technology of Japan.

### REFERENCES:

- [1] R. Kimura, S. Wada, Nucl. Sci. Eng., **193** (2019) 1013-1022.
- [2] O. Iwamoto *et al.*, J. Nucl. Sci. Technol., **60** (2023) 1-60.
- [3] K. Shibata *et al.*, J. Nucl. Sci. Technol., **48** (2011)1.
- [4] D. Sieman *et al.*, Nucl. Sci. Eng., **197** (2023)14-24.

## CO2-6 Measurement of C-13 neutron cross-section for new nuclear battery

T. Wallace-Smith<sup>1</sup>, T. Scott<sup>1</sup>, Y. Takahashi<sup>2</sup>, k. Terada<sup>2</sup>, J. Hori<sup>2</sup>

<sup>1</sup>SouthWest Nuclear Hub, University of Bristol

<sup>2</sup>Institute for Integrated Radiation and Nuclear Science, Kyoto University

### INTRODUCTION:

The UK houses 60% of the world's store of irradiated nuclear graphite waste totalling 90,000 tonnes, with Japan also housing large quantities in repositories. This waste contains several key radioisotopes which contribute significantly to the total activity of the waste. Tritium and Carbon-14 are highlighted as commercially useful radioisotopes each with a half-life of 12.32 and 5,700 years respectively. In extracting value from nuclear waste via radioactive material, this reduces the cost burden on Governments in storing waste as removing activity lowers the waste level rating from high to low-level. These beta-emitting radioisotopes are ideally suited for use in beta-voltaics as the energy released during radioactive decay can be harvested using specialised semiconductors. The University of Bristol has several decades experience in the fabrication of such semiconductors like Chemical Vapour Deposition (CVD) diamond, which is exceptionally radiation hard and chemically inert. By incorporating Tritium and C-14 into CVD diamond a highly efficient beta-voltaic power cell can be formed, capable of lasting for decades to centuries with a wide range of uses spanning from the internet of things (IoT) to space exploration. Determining the overall quantity of C-14 in graphite waste poses several challenges, where the best approach is to simulate the burnup of nuclear fuel within a reactor where graphite shielding, or moderator material is used. However, these simulations rely on the nuclear data libraries which are based upon fundamental experimental data. In the case of C13(n,  $\gamma$ )C14, the data is sparse and has a large degree of uncertainty, as seen in Figure 1. Where the latest published experiments which contributed to nuclear data were performed by A. Wallner et al in 2016<sup>1</sup> are expressed as 3 red points. These 3 data points revealed a large resonance in C-13, changing the overall predicted Carbon-14 content in graphite waste by a large degree.

In this project, a new approach to measuring the neutron cross section of C-13 is suggested where multiple methods are used to cross-check one another. Previous work by A. Wallner used sub-1-gram samples irradiated in a nuclear reactor where the generated C-14 was measured by Accelerated Mass Spectrometry (AMS), a method usually associated with carbon dating. At the University of Bristol, the largest ever high purity (>99%) C-13 sample has been prepared by a newly developed method of ethanol slurry compaction, weighing 60 grams. The sample will be neutron irradiated at the Tokyo-Tech using the Pelletron Accelerator where secondary gammas from the C13(n,  $\gamma$ )C14 reaction will be detected, allowing

for the measurement of the neutron capture cross section. Additionally, smaller samples will be irradiated at KUR in KURNS for AMS measurements, neutron scattering and activation-analysis. The combined method has never been deployed on a single sample to measure all aspects of neutron interaction in this way. By measuring the C13 neutron interaction cross sections in unparalleled detail, allowing for a more accurate calculation of the quantity of C-14 which can be reused for producing beta-voltaic devices, strengthening the case for repurposing otherwise value-less nuclear waste.

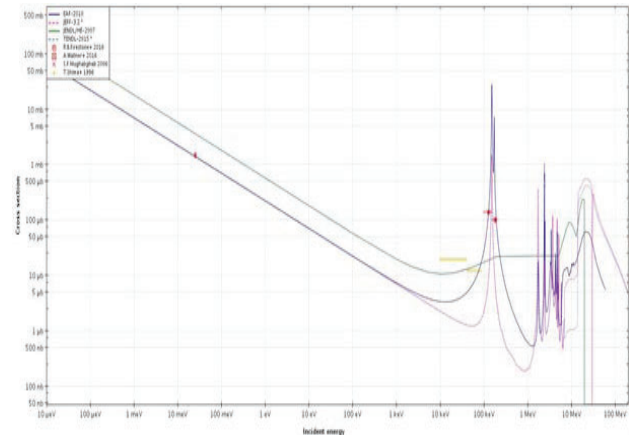

Fig. 1. C13(n,  $\gamma$ )C14 neutron capture cross section from different nuclear data libraries and experiments. The three dots in red represent the 2016 AMS experiments by A. Wallner.

For the prototype Tritium beta-voltaic device, a brand-new manufacture method has been developed. Wherein the diamond Schottky structure, consisting of an ohmic (Boron doped) and Schottky junction, undergoes ion implantation with Helium-3 which quickly transmutes to Tritium during neutron irradiation. This allows for incorporation of Tritium into the diode lattice, improving device efficiency from the previous documented maximum of 24% for radioactive sources situated outside of the lattice, to above 60%. By April 2022, He-3 implanted CVD diodes will be manufactured at the University of Bristol ready for irradiation.

### EXPERIMENTS and PRESENT STATUS

Several smaller 1-gram pellets as well as seventeen 20 mg samples in vacuum-sealed ultrapure quartz vials had been prepared for Pelletron accelerator experiment and KUR reactor irradiation. The sample has been irradiated in the hydraulic neutron irradiation chamber at KUR. The sample is currently cooling in KURNS, and we plan to conduct beta ray measurements after cooling.

### REFERENCES:

[1] A. Wallner *et al.*, Phys. Review, C93 (2016) 045803.

## CO2-7 Measurement of Energy Resokution in the KURNS-LINAC Pulsed Neutron Facility[3]

T. Sano, Y. Matuo, T. Kanda, Y. Takahashi<sup>1</sup>, K. Terada<sup>1</sup>, H. Yashima<sup>1</sup> and J. Hori<sup>1</sup>

Atomic Energy Research Institute, Kindai University  
<sup>1</sup>Institute for Integrated Radiation and Nuclear Science,  
 Kyoto University

**INTRODUCTION:** The electron linear accelerator at the Research Reactor Institute, Kyoto University (KURRI-LINAC) had been originally established in 1965 by the High Voltage Engineering Co., USA and started as a 23 MeV machine. In 1971, the machine power had been increased to 46 MeV. The KURRI-linac has two different operation pulse modes. One is a long mode with a maximum repetition rate of 120 Hz, a pulse width of 0.1–4.0  $\mu$ s and a peak current of about 0.5 A for the measurement at low energies below 10 eV. Another is a short mode with a maximum repetition rate of 300 Hz, a pulse width of 2–100 ns and a peak current of about 5 A for the measurement at high energies above 1 eV. It is worth noting that the peak current of short mode is ten times as large as that of long mode. In measurements of nuclear data, a water-cooled tantalum (Ta) target as a photo-neutron target and a light water moderator are used. There are two kinds of the moderator. One is a water tank type and another is an octagonal shape moderator called “pac-man type”. In order to measure accurate nuclear data, it is very important to evaluate the energy resolution ( $\Delta E/E$ ) of a moderator. In 2021, measurement and detail evaluation of energy resolutions for the water tank type moderator has been carried out [1]. In that experiment, prompt gamma radiation from a sample was measured using 12 BGO detectors. The signals from each BGO detector were integrated by a Dual Sum Inverter. It is necessary to evaluate a contribution of that signal integration to the energy resolution.

Then, TOF measurements were performed with and without the Dual Sum Inverter. In the experiment without the Dual Sum Inverter, TOF measurement was performed using a single BGO detector.

**EXPERIMENTS:** In this study, the energy resolution of KURNS-LINAC was obtained by transmitted neutron flux via <sup>181</sup>Ta sample. In order to measure a TOF spectrum, a cylindrical moderator tanks which have 19 cm diameter and 30cm height was installed at the target room. The tanks were filled with light water. We used the neutron at “12 m room” which is located on 135 deg. axis from the electron beam line. The flight path of neutron flux between the sample and the moderator was 12.65 m as shown in Fig.1. The two <sup>181</sup>Ta samples which has 0.2 mm and 0.03 mm thickness were employed to consider self-shielding effects at each resonance. The TOF spectrum was measured with 12 BGO detectors or single BGO detector. The signal circuits are shown in Fig.2 and Fig.3. In the experiments, the beam frequency and pulse-width of KURNS-LINAC were 200 Hz and 100

nsec.

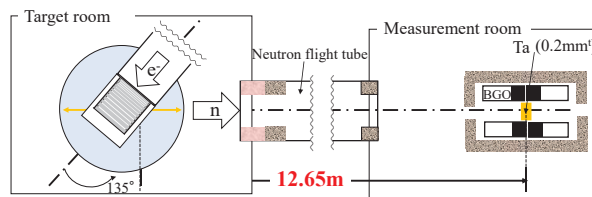

Fig. 1. Experimental geometry.

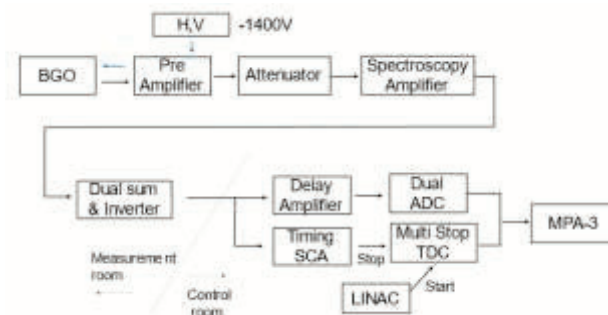

Fig. 2. Signal circuits with a single BGO detector.

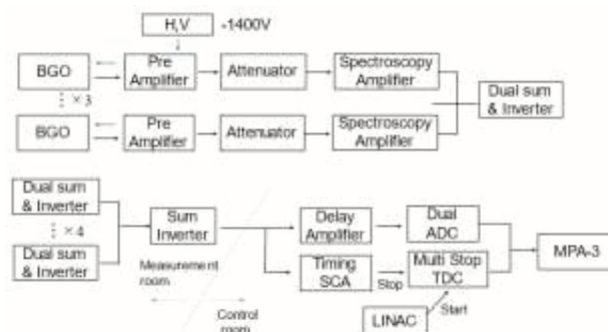

Fig. 3. Signal circuits with 12 BGO detectors.

**RESULTS:** The energy resolutions were evaluated by comparison between the experimental and the calculated values of FWHM at the resonance absorptions in the obtained TOF spectrum. For the first and second resonances, the sample with 0.03 mm thickness was used for evaluation, and for other resonances, the results of the 0.2 mm thick sample were used. As the results, there was no significant difference of the energy resolutions between the single and 12 BGO systems. Therefore, the contribution of the Dual Sum Inverter to the time resolution of the TOF measurement is sufficiently small.

### REFERENCES:

- [1] Y. Matsuo, *et. al.*, AESJ 2022 spring meeting, (2022) 2A07.

## CO2-8 Search for Tetraneutron Bound State Emitted with Uranium Fission

H. Fujioka, R. Tomomatsu, K. Takamiya<sup>1</sup>

*Department of Physics, Tokyo Institute of Technology  
<sup>1</sup>Institute for Integrated Radiation and Nuclear Science,  
Kyoto University*

**INTRODUCTION:** Whereas typical atomic nuclei are composed of both protons and neutrons, there are various attempts to search for multi-neutron systems, such as tetraneutron ( ${}^4\text{n}$ ), which consists of four neutrons. Recently, two experimental groups independently reported positive results on the existence of tetraneutron. T. Faestermann *et al.* used the  ${}^7\text{Li}({}^7\text{Li}, {}^{10}\text{C}){}^4\text{n}$  reaction to populate tetraneutron, and found a peak in the  ${}^{10}\text{C}$  energy spectrum. They interpreted it as an indication of the formation of a bound tetraneutron with the binding energy of  $0.42 \pm 0.16$  MeV [1]. On the other hand, M. Duer *et al.* observed a resonance-like structure of tetraneutron in the missing-mass spectrum of the  ${}^8\text{He}(\text{p}, \text{p}{}^4\text{He}){}^4\text{n}$  reaction [2], and they extracted an energy of  $2.37 \pm 0.38(\text{stat.}) \pm 0.44(\text{sys.})$  MeV and a width of  $\Gamma = 1.75 \pm 0.22(\text{stat.}) \pm 0.30(\text{sys.})$  MeV. While the latter result suggests the tetraneutron would fall apart into four neutrons, the former result implies the tetraneutron would decay via weak interaction, i.e.  ${}^4\text{n} \rightarrow {}^4\text{H} + e^- + \bar{\nu}_e$ , with a substantially long lifetime. The existence of a tetraneutron system as a resonance or a bound state is still an open question.

If the tetraneutron system is a bound system of four neutrons, it may activate an isotope in a sample by inducing a secondary reaction, such as a ( ${}^4\text{n}, \text{n}$ ) reaction. Tetraneutron search with the activation technique had been extensively utilized in the 1960s and 70s, based on the hypothesis that the tetraneutron bound state could be produced in fission [3]. In particular, samples of amitrole ( $\text{C}_2\text{H}_4\text{N}_4$ ) and pure aluminum were irradiated in a nuclear reactor, CP-5, to search for a signature of  ${}^{17}\text{N}$  and  ${}^{28}\text{Mg}$ , respectively, resulting in a negative result [4]. An upper limit of the production rate of  $5 \times 10^{-9}$  per fission was deduced.

Motivated by the recent findings, we revisited the approach in Ref. [4], and proposed an irradiation experiment at KUR, adopting an approach similar to the instrumental neutron activation analysis. It should be worth stressing that this approach is sensitive only to the bound tetraneutron, which can escape from the fuel elements. Its existence can be addressed in term of the production rate per uranium fission.

**METHOD:** We adopted a  ${}^{88}\text{Sr}$  sample in the form of strontium carbonate ( $\text{SrCO}_3$ ). The primary reason to use  ${}^{88}\text{Sr}$  is that  ${}^{91}\text{Sr}$ , which is to be produced in the  ${}^{88}\text{Sr}({}^4\text{n}, \text{n})$  reaction, has a moderately long half-life and emit 750 keV and 1024 keV  $\gamma$  rays ( $I_\gamma=0.237(8)$  and  $0.335(11)$ ) after its  $\beta$  decay. Another important aspect is that the neutron capture cross section of  ${}^{88}\text{Sr}$  is not too large, and the product  ${}^{89}\text{Sr}$  hardly emits  $\gamma$  ray (only 909 keV  $\gamma$  ray with  $I_\gamma=9.56(5) \times 10^{-5}$ ) after its  $\beta$  decay, which enables us to irradiate the sample for a long time at the center of the reactor core without inducing

high radioactivity.

Two kinds of samples, strontium carbonate with natural abundance ( $\text{SrCO}_3$ ) and  ${}^{88}\text{Sr}$ -enriched strontium carbonate ( ${}^{88}\text{SrCO}_3$ ), were irradiated in November 2022 and February 2023, respectively. In the first irradiation, we confirmed that  ${}^{85}\text{Sr}$  (half life: 64.849(7) days),  ${}^{85}\text{Sr}^{\text{m}}$  (half life: 67.63(4) minutes), and  ${}^{87}\text{Sr}^{\text{m}}$  (half life: 2.815(12) hours) are main sources of  $\gamma$ -rays, even though the natural abundances of  ${}^{84}\text{Sr}$  and  ${}^{86}\text{Sr}$  are much smaller than that of  ${}^{88}\text{Sr}$ , in accordance with our expectation. Based on the result, the experimental plan in February 2023 has been established. A 570-mg  ${}^{88}\text{SrCO}_3$  sample was irradiated at the center of the reactor core for two hours, using the hydraulic conveyer. After the irradiation, it was cooled for half a day before treatment. Then, we measured  $\gamma$  rays from the  ${}^{88}\text{SrCO}_3$  sample with a germanium detector. We repeated the 30-minutes measurements for 48 times.

**PRELIMINARY RESULT:** Figure 1 displays a preliminary  $\gamma$ -ray energy spectrum. In addition to two prominent photopeaks and their escape peaks from  ${}^{24}\text{Na}$ , we have identified the photopeak due to  ${}^{87}\text{Sr}^{\text{m}}$ , which was produced by neutron capture in  ${}^{86}\text{Sr}$  in the sample (abundance: 0.02%), and many photopeaks due to bromine contamination in a silica tube. If  ${}^{91}\text{Sr}$  isotopes were produced in the  ${}^{88}\text{Sr}({}^4\text{n}, \text{n})$  reaction, we would expect to observe 750 keV and 1024 keV photopeaks in the spectrum. We are carefully analyzing the spectra to evaluate the area of these photopeaks, which is necessary to deduce the production rate of tetraneutron bound states in uranium fission.

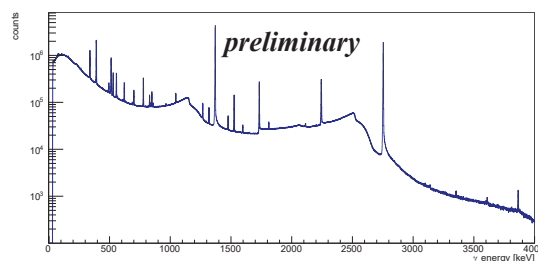

Fig.1. The  $\gamma$ -ray energy spectrum from the  ${}^{88}\text{SrCO}_3$  sample. The data from 48 sets of 30-minute measurements are combined.

**ACKNOWLEDGMENT:** This work is supported by Grant for Basic Science Research Projects from the Sumitomo Foundation.

### REFERENCES:

- [1] T. Faestermann *et al.*, Phys. Lett. B, **824** (2022) 136799.
- [2] M. Duer *et al.*, Nature, **606** (2022) 678.
- [3] F. Miguel Marqués and J. Carbonell, Eur. Phys. J. A., **57** (2021) 105.
- [4] J.P. Schiffer and R. Vandenbosch, Phys. Lett., **5** (1963) 292.